

RedHeader RO™ framing details:

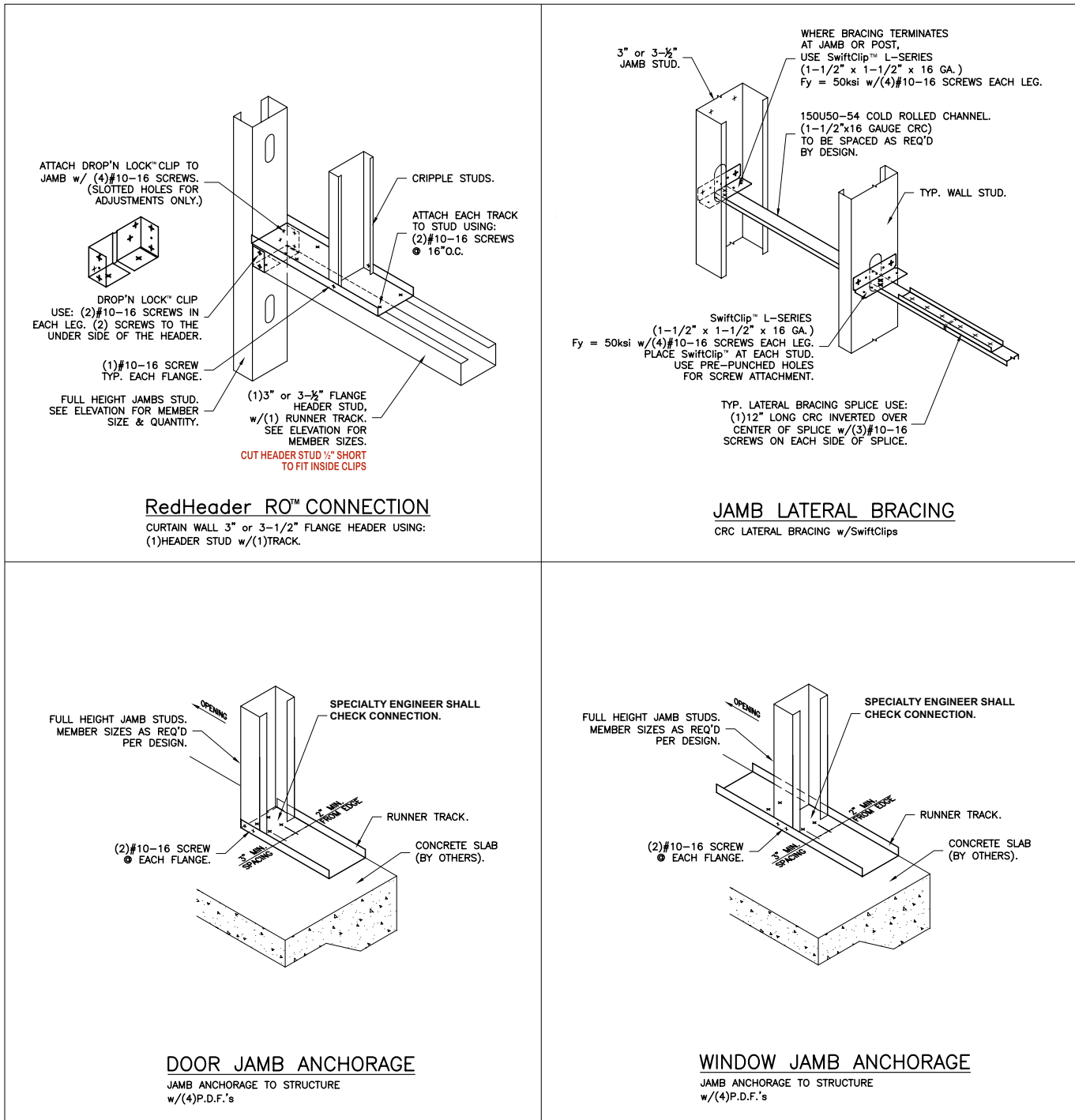

RedHeader RO design advantages:

ClarkWestern Design (CWD) & Technical Services are here to support you

- Drop 'N Lock Clip is ICC tested for vertical and horizontal loads.
- Use our RedHeader RO sizing sheet attached for quick preliminary sizing from ClarkWestern's technical department allowing you to see the advantages of using the opening system compared to the typical systems.
- Contact Technical Services at 888-437-3244

ClarkWestern Design Gold Seal™ Engineering Service

- CWD Engineering Service offers a complete shop drawing package using the RedHeader RO framing system simplifying the submittal process.
- Contact CWD toll free at 1-877-832-3206.