

**Calculated Loads for Screw Connections**

Calculation Sheet: Screws-01

**AISI Calculated Allowable Loads for Screw Connection**

Material Thickness (mils)	Design Thickness (in)	Material Strength		#8-18 HWH Screw		#10-16 HWH Screw		#12-14 HWH Screw		1/4"-14 HWH Screw	
		F <sub>v</sub>	F <sub>u</sub>	Dia.=0.16		Dia.=0.190		Dia.=0.21		Dia.=0.240	
		(ksi)	(ksi)	Shear (lbs)	Tension (lbs)	Shear (lbs)	Tension (lbs)	Shear (lbs)	Tension (lbs)	Shear (lbs)	Tension (lbs)
33	0.0346	33	45	162	71	177	84	186	93	199	106
43	0.0451	33	45	241	92	263	109	277	121	296	138
54	0.0566	33	45	333	115	370	137	389	152	416	173
	0.0566	50	65	333	167	467	198	562	219	600	250
68	0.0713	33	45	n/a	n/a	467	173	550	191	588	218
	0.0713	50	65	n/a	n/a	467	249	625	276	849	315
97	0.1017	33	45	n/a	n/a	467	246	625	272	863	311
	0.1017	50	65	n/a	n/a	467	356	625	393	863	450
118	0.1242	33	45	n/a	n/a	n/a	n/a	625	333	863	380
	0.1242	50	65	n/a	n/a	n/a	n/a	625	480	863	549

**Minimum Required Allowable Load for Screws**

Material Thickness (mils)	Design Thickness (in)	#12-24 HWH Screw		#1/4"-28 HWH Screw	
		Dia.=0.21		Dia.=0.240	
		Shear (lbs)	Tension (lbs)	Shear (lbs)	Tension (lbs)
Steel	0.1875	725	1042	957	1100
	0.25	725	1063	957	1425

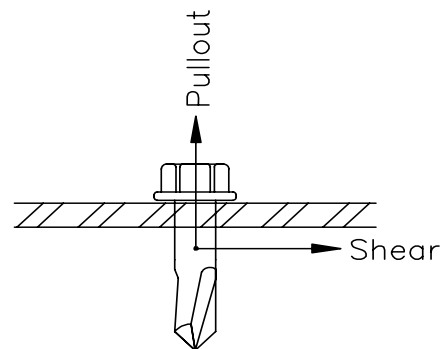

**Screw Table Notes:**

- 1.) All values were calculated using the 2001 AISI Specification
- 2.) Shear values were based on the tilting and bearing modes of failure Eq. E4.3.1-1, E.4.3.1-2
- 3.) Minimum Spacing of Screws is determined by E4.1 stating spacing shall not be less than 3d
- 4.) Edge Distance is determined by E4.2 stating that edge distance shall not be less than 3d
- 5.) Allowable loads are based on a Safety Factor of 3.0
- 6.) E4.3.2 states that the Bearing Strength <math>P\_{ns} = t \cdot e \cdot F\_u</math>
- 7.) For the screws into structural steel, the shear values are for the failure of the screw itself. Look at bearing of clip to determine minimum value of shear.
- 8.) Bearing or Pullover values do not control in the above cases.