

Stud Spacing (in)	16
Gap (in)	1
Track Leg Length (in)	3
Ω (ASD)	2.80

	25GA	22GA	20GA-D	20GA-S	18GA	16GA	14GA	12GA
t	0.0188	0.0283	0.0312	0.0346	0.0451	0.0566	0.0713	0.1017
Beff	16.00	16.00	16.00	16.00	16.00	13.67	11.28	8.89

Allowable Slip Track Point Load								
Yield Strength	25GA	22GA	20GA-D	20GA-S	18GA	16GA	14GA	12GA
33	17	38	46	56	96	129	N/A	N/A
50	N/A	N/A	N/A	N/A	145	195	256	411

$$beff = 0.11 \times \alpha^2 \times (e^{0.5} / t^{1.5}) + 5.5 \times \alpha \leq S$$

$$Pn = (beff \times t^2 \times Fy) / (4 \times e \times \Omega)$$

$$\text{Track Leg Length} = (2 \times e) + 1$$

Where:

Pn = Nominal capacity of the slip track leg (kips)

beff = effective width of resisting track flange (in)

t = Nominal thickness of the slip track (in)

Fy = Yield Strength of track (ksi)

e = Design slip track

α = conversion coefficient: 1.0 when e,t, and S are in (in)

25.4 when e,t, and S are in (mm)

Ω = ASD Factor of Safety 2.8

S = center-to-center spacing of studs (in)

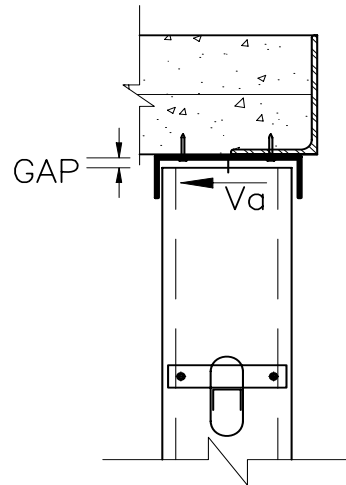

Notes:

1. Values include 1/3 increase in allowable stress for short-term loading.
2. Install one row of lateral bracing within 12" of slip track to prevent studs from rotating.
3. Equations from LGSEA Tech Notes April 2004, and James Gerloff 2004 "Cold-Formed Steel Slip-Track Connection" Master Thesis located at <http://www.msoe.edu/~gerloffj>

Calculations for slip track point load (Va in diagram above):

$$Va = (\text{wind pressure psf}) \times (\text{spacing ft}) \times (\text{wall stud length ft}) / 2$$

$$\text{EXAMPLE: } (20\text{psf}) \times (1.33') \times (15.5') / 2 = 206.2 \#$$

Wind pressure	20	psf	
Stud Spacing	1.33	ft	(12"o.c.=1'; 16"o.c.=1.33'; ect.)
Wall Stud Length	20	ft	
=	532	/ 2=	266 Maximum allowable slip track point load (lb)